

# Meat Gear

CUTTING BAND SAW MACHINE  
CODE: SIE305AIHER5HP3P  
BRAND: MEAT GEAR  
MODEL: 305 PLUS

Instructions for operation, service and  
maintenance

Congratulations on your purchase!  
You have just acquired a high quality Meat Gear Machine  
Please read carefully before using your new BAND SAW MACHINE.

Meat  
Gear

Content	Page
Introduction	(3)
Parts	(4)
Warning	(5)
Unpacking	(5)
Installation	(6)
Operation	(7)
Recomendations	(7)
Cleaning machine	(8)
Maintenance	(8)
Electric diagram	(9)
Warranty	(10)
How to obtain	(11)



It is important that you and the person operating the machine reads carefully this operation manual.

## Introduction

The cutting band saw machine model 305 plus is made of stainless steel. This model is the ideal machine for a high demand market, you will find it at supermarkets, meat industry markets, among other examples. This model can be designed with a 3 horsepower (HP) motor or a 5 HP motor and either Triphasic or monophasic.

Characteristics	Value	Unit
Voltage Supply	220(3)	Volts (phases)
Frequency	60	Hz
Current	9/11	Amps
Engine Power	3/5	HP
Machine Weight	485	Pounds
Saw Velocity	105/52.5	Ft/Sec
Lenght of Saw Blade	120/305	Inches/Cm



"Disconnect the machine from electric output before following the next instructions."

## Parts

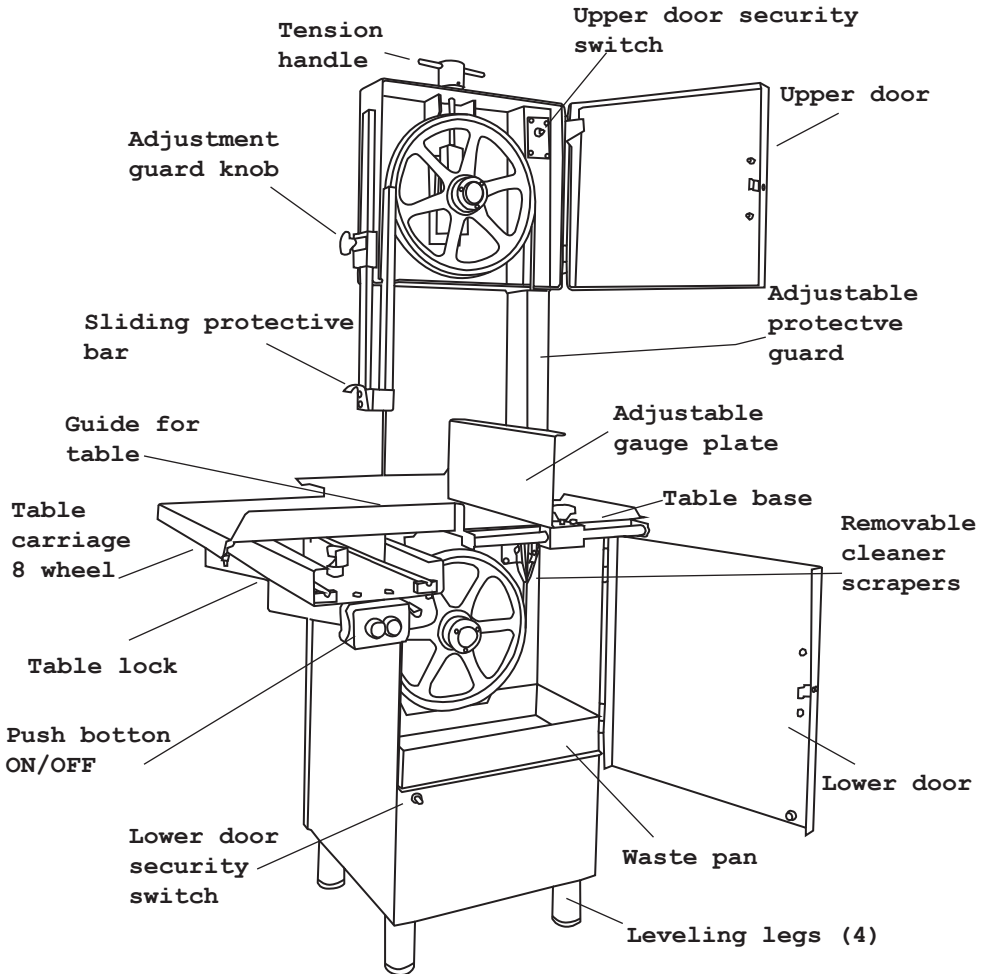



"It is important that the owner and the person operating this machine carefully reads the content of the manual of operation, service and maintenance before using it."

## Warning

- The meat equipment machinery is designed to cut meat, bone, and other food industry related products. Due to its nature, if not used properly or without the due knowledge to operate the machine, its misuse can be of extreme danger to the person operating the machine.
- Do not allow children, minors and people without the knowledge or experience on how to use the machine, operate it.
- Don't use your hands to maneuver the product about to be sliced when the distance is less than 4 inches from the cutting blade to the product. In case of not following instructions the operator could suffer from severe injuries or mutilations.
- Never leave the electricity output connected while doing any maintenance service, cleaning or other service
- While using the machine, make sure that there aren't any loose parts or moving parts since it may cause an injury or amputate the operator. Make sure the protective guard is in place and keep your hands from a safe distance of the cutting band saw blade.
- Always, before cleaning the machine, make sure you've turned off and disconnected the electric output.

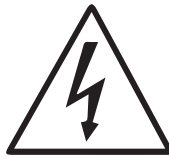

## Unpacking

Make sure that you have all the following parts and that each is in good condition.

- SCRAP TRAY
- MANUAL OF OPERATION, SERVICE MAINTENANCE
- CARRIAGE
- TABLE ASSY
- 4 SPARE BAND SAWS 120"
- 2 SPARE FIBER GUIDES
- 4 RUBBER BUMPERS FOR LEVELING LEGS



**"Disconnect the machine from electric output before following the next instructions."**

## **Installation**

1- Place the machine in a clean, dry and leveled surface. In order to level the machine and have better stability, you must adjust the leveling legs and place the rubber foot. Make sure that your electric output has a groundable point and a thermally protected outlet, this will give better protection to your machine. Place the 4 rubber bumpers once the machine is positioned.

2- The table carriage can easily move sideways to facilitate the operators job. To prevent the table from falling, place the stop carriage block, you can unlock it for cleaning purposes. Install the table assy by placing both rods on each base hole and once its correctly placed, then use the lock lever.

3- How to change and adjust saw blade: this machine has an automatic adjustable tension system, which helps the saw blade reach its ideal tension, the correct alignment with the upper/lower pulleys and guides. This system is designed to maximize the meat saw machine potential and help the operator have better cuts, less waste and prolong the saw blade's life.

4- The equipment already includes the saw blade. Open the upper and lower door, rotate the tension handle in clockwise direction until you hear a "CLICK" and see the handle jump. This sound and movement will indicate us that you have reached the required tension for the machine. Once you've done this, make sure the pulley and saw blade move freely throughout the machine.

5- Changing the saw blade: Open the upper and lower doors, remove the mobile protective guard and push upperwise to set free both guides. Rotate the tension handle counterclockwise until you see the saw blade loose and you can remove it. There's no need to loosen up for completely the tension handle, just enough so you can remove it. Move the nylon guide upperwise and place the saw blade in between the scrapers and upper and lower guides making sure that the teeth of the saw blade are facing down to get a correct cut. Once correctly placed, rotate the tension handle in clockwise direction, once you hear click and can correctly rotate the upper and lower pulley, place the mobile protective guard again in it's original place and lower down the nylon guide so it's at the same level as the stainless steel one.

6- Place waste tray below the lower pulley so waste accumulates there and clean up is easier.

7- Once you've finished all the above steps, the machine should be ready to use.



**"It is important that the owner and the person operating this machine carefully reads the content of the manual of operation, service and maintenance before using it."**

## Operation

- 1- Adjust the thickness of the cut using the gauge plate assy
- 2- Place the product in the carriage table.
- 3- Adjust the protective guard leaving exposed only the cutting saw blade that is going to be used.

**WARNING: ALWAYS ADJUST THE PROTECTIVE GUARD WHEN THE MACHINE IS TURNED OFF AND DISCONNECTED TO POWER OUTPUT**

- 4- Turn on the machine by pushing the green button. make sure both upper and lower door are closed since the security interruptor will prevent the equipment from turning on if not correctly closed.
- 5- Press the product against the gauge plate assy and don't place your fingers or hands close to the cutting saw blade. Make sure to turn OFF the machine while not using it and keep it disconnected from the power output.



**"It is important that the owner and the person operating this machine carefully reads the content of the manual of operation, service and maintenance before using it."**

## Recommendations

- 1- Don't force the cut into the blade. Make sure the cutting band blade has enough sharpness to make the perfect cut go smoothly against the meat. In case it isn't cutting as smoothly as it should you should try changing the cutting band saw blade. It's important to remember that every cutting band saw blade has it's durability and it's better to change the blade saw than to waste product having a bad cut.
- 2- Make sure the lower guide and the nylon guide are free from any waste or item blocking them. since its purpose is to clean the waste on the saw machine. Make sure that the cutting band saw blade passes throughout.
- 3- Make sure the scrapers are making contact with the lower pulley and saw blade. this will make your machine work better. Change in case of wear or tear. The lower pulley has scrapers in order to prevent waste from stying in the cutting band saw blade and causing the machine to have problems.
- 4- Always use frozen meat.

## **Cleaning machine**

- 1- Never use cleaning supplies that have chlorine, vinegar or any citric acid. These supplies can cause damage to the stainless steel protective layer and show oxidation.
- 2- Open the upper and lower doors and with a hose water down all the waste that's inside the machine.
- 3- After doing step 2, use a soft brush and detergent mixed with water. Clean all the cutting band saw machine areas. Make sure to not use a spatula or sharp objects that can damage the stainless steel protective layer.
- 4- You can use a hose to splash water directly into the machine, your equipment is fully protected for this, just make sure there's no water leak into the motor cabinet.

## **Maintenance**

- 1- Blade: Daily: Check the sharpness every day to make sure that you're getting the best cut and not wasting any product by forcing a cut
- 2- ON and OFF button: Daily: Make sure that the buttons are in a good state, in case they present damage, the machine could have trouble turning ON or OFF
- 3- Guides: Daily: Make sure it's not broken or have any visible damage. It's incorrect state can cause the cutting band saw blade to move while using the machine and have a negative effect with the cut.
- 4- Scrapers: Weekly: Make sure that it's correctly aligned and fulfilling its task. In case you see damaged scrapers, make sure to replace it since the damage can cause the machine to stop working.



Electric diagram

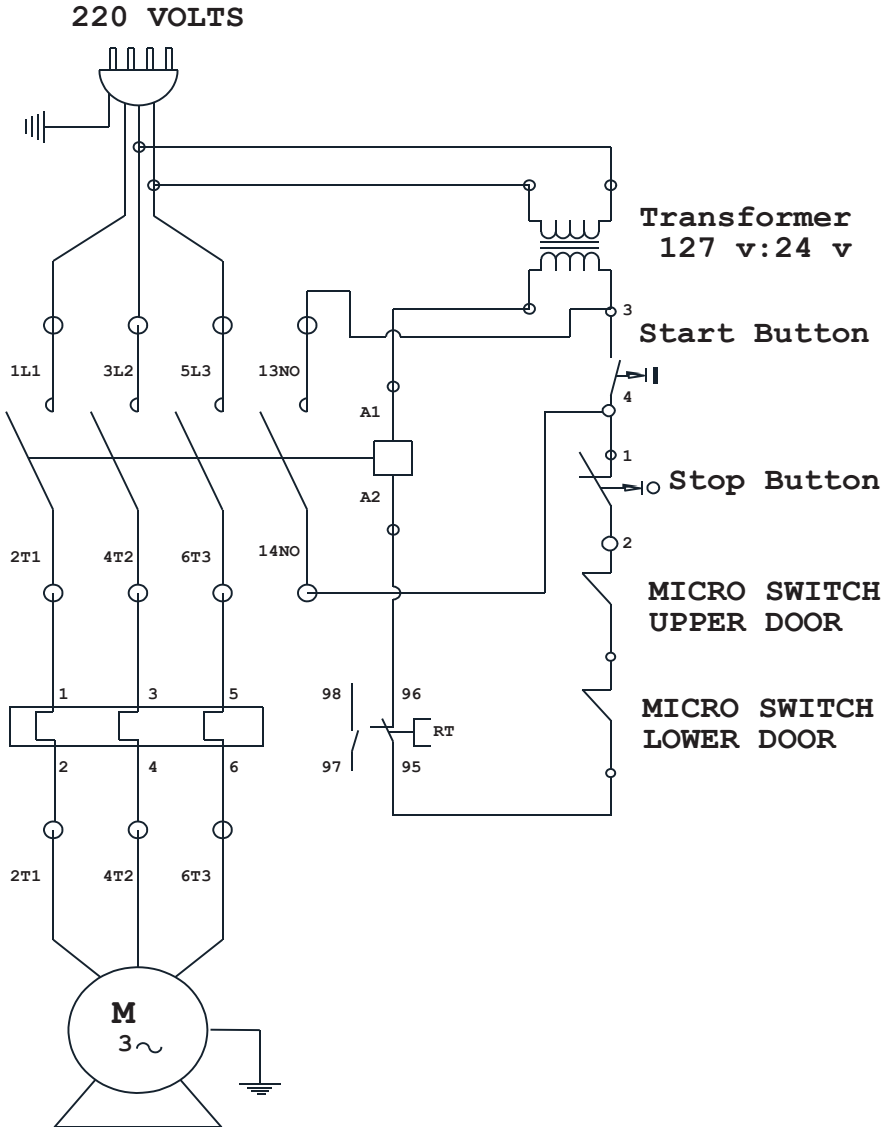

## **LIMITED WARRANTY (1) YEAR WARRANTY**

Meat Gear warrants this product against defects in materials or workmanship for a period of one year from the date of original purchase.

Should any manufacturing defect be discovered within one year from date of purchase, you must deliver the entire product to the MEAT GEAR dealer that sold it or to a MEAT GEAR service center in its original packaging or in packaging affording an equal degree of protection, along with proof of purchase. MEAT GEAR will at its option, repair or replace or an exchange basis with an equal or equivalent unit. The defective unit, without charge for parts and labor. The transportation and insurance charges to and from the MEAT GEAR service center are not included in this warranty.

### **WHAT THIS WARRANTY DOES NOT COVER.**

This warranty covers only normal consumer use in Canada and the United States. This warranty does not cover worn parts, which die to the nature of the machine, have a limited usable life, and have to be replaced on a use and wear basis, nor:

- A) Damage caused by disasters such as fire, flood, lightning, improper electrical current.
- B) Improper or inadequate installation.
- C) Improper or inadequate maintenance.
- D) Unauthorized modification or misuse.
- E) Damage caused by service other than by an authorized MEAT GEAR service center.

### **LIMITATIONS OF WARRANTY.**

NEITHER MEAT GEAR OR ANY THIRD PARTY SUPPLIERS MAKES ANY OTHER WARRANTY OF ANY KIND, WHETHER EXPRESS OR IMPLIED, WITH RESPECT TO MEAT GEAR PRODUCTS. THIS WARRANTY IS EXCLUSIVE AND IN LIEU OF ALL OTHER EXPRESS WARRANTIES AND UNLESS STATED HEREIN, ANY STATEMENTS OR REPRESENTATIONS MADE BY OTHER PERSON OR FIRM ARE VOID. THE DURATION OF ANY IMPLIED WARRANTIES OF MERCHANTABILITY OR FITNESS FOR A PARTICULAR PURPOSE ON YOUR MEAT GEAR PRODUCT SHALL BE LIMITED TO THE DURATION OF THE EXPRESS WARRANTY SET FORTH ABOVE, EXCEPT AS PROVIDED IN THIS WRITTEN WARRANTY NEITHER MEAT GEAR NOR TIS AFFILIATES SHALL BE LIABLE FOR ANY LOSS, INCONVENIENCE, OR DAMAGE, RESULTING FROM THE USE OR INABILITY TO USE THE MEAT GEAR PRODUCT, WHETHER RESULTING FROM BREACH OF WARRANTY OR ANY OTHER LEGAL THEORY.

Some states do not allow limitations on how long an implied warranty lasts and some states do not allow the exclusion or limitation of incidental or consequential damages, so the above limitation and exclusion may not apply to you.

This warranty gives you specific legal rights, and you may also have other rights which vary from state to state.

## **HOW TO OBTAIN WARRANTY AND SERVICE**

- 1- Refer to the troubleshooting guide in your owner's manual. This list might solve your problem.
- 2- Call the MEAT GEAR dealer that sold the product at +1 (800) 824-1644 / (832) 675-9699 within 30 days after you find a defective product or part for tech assistance.
- 3- If you have to ship a MEAT GEAR service center be sure to obtain a Service order number from the MEAT GEAR service center at +1 (800) 824-1644 / (832) 675-9699
- 4- Arrange for the delivery of the product to the authorized MEAT GEAR service center. Products shipped to the service station must be insured and safely and securely packaged, preferably in the original carton, and a letter explaining the defect and also a copy of the bill of sale or other proof of purchase must be enclosed.
- 5- Make sure to include inside the package a complete description of the defect or trouble with the unit and complete name, address, and more phone numbers of who to contact for more questions and who to ship to.
- 6- And also make sure to clearly write outside of the package the service order number and the full address for the MEAT GEAR service center.

### Contact

MEAT GEAR  
www.meatgear.mx  
+1 (800) 824-1644 / (832) 675-9699  
sales@meatgear.mx

Find more technical information  
at [meatgear.mx](http://meatgear.mx)

**Meat  
Gear**