

Meat
Gear

POULTRY CUTTER



User Manual



It is extremely important that you and/or the equipment operator carefully read the contents of this operation, maintenance and service manual

Contents

- 1** | **Contents**
- 3** | **Warnings**
- 4** | **Unpacking**
- 4** | **Parts**
- 5** | **Installation**
- 5** | **Operation**
- 6** | **Cleaning**
- 6** | **Maintenance**
- 8** | **Electric diagram**
- 9** | **Warranty**
- 10** | **How to obtain warranty**



It is extremely important that you and/or the equipment operator carefully read the contents of this operation, maintenance and service manual

Warnings

Our Poultry cutters have been developed to be highly efficient, ideal for daily hard work, easy to operate. For its characteristics it is recommended to be used in butcher shops, hotels, food processing factories, industrial dining halls, among others.

Please take in to account all the recommendations and precautions in this user manual to guarantee its optimal functioning.

- This machine has been designed to cut food products, the unit is dangerous by its nature and should be used only for this purpose.
- Do not allow untrained personnel to operate this equipment.
- Do not perform cleaning or maintenance to the machine while on or connected to a power source.
- To sharpen the knife, its necessary to do it while in operation. Extreme cautions and place your fingers far from the blade.
- Use cut resistant steel gloves while maintenance or cleaning.
- Turn off the machine while its not being used.

Note: This equipment should be connected to a thermally protected connection. Check the power requirements of the unit and be sure that it matches the power source you have available. Any electrical cords should be replaced by professional personnel if needed.



It is extremely important that you and/or the equipment operator carefully read the contents of this operation, maintenance and service manual

Unpacking

While unpacking the unit, make sure all the pieces are complete.

A. Open the box, lift the poultry cutter by the motor and base to remove from the box.

Do not lift the equipment by the knife or by the knife protector, this may cause accidents.

Make sure the number of rubber legs is complete (4).

B. Lift the machine and carefully remove the knife protector.

C. Place the poultry cutter in a leveled, clean surface.

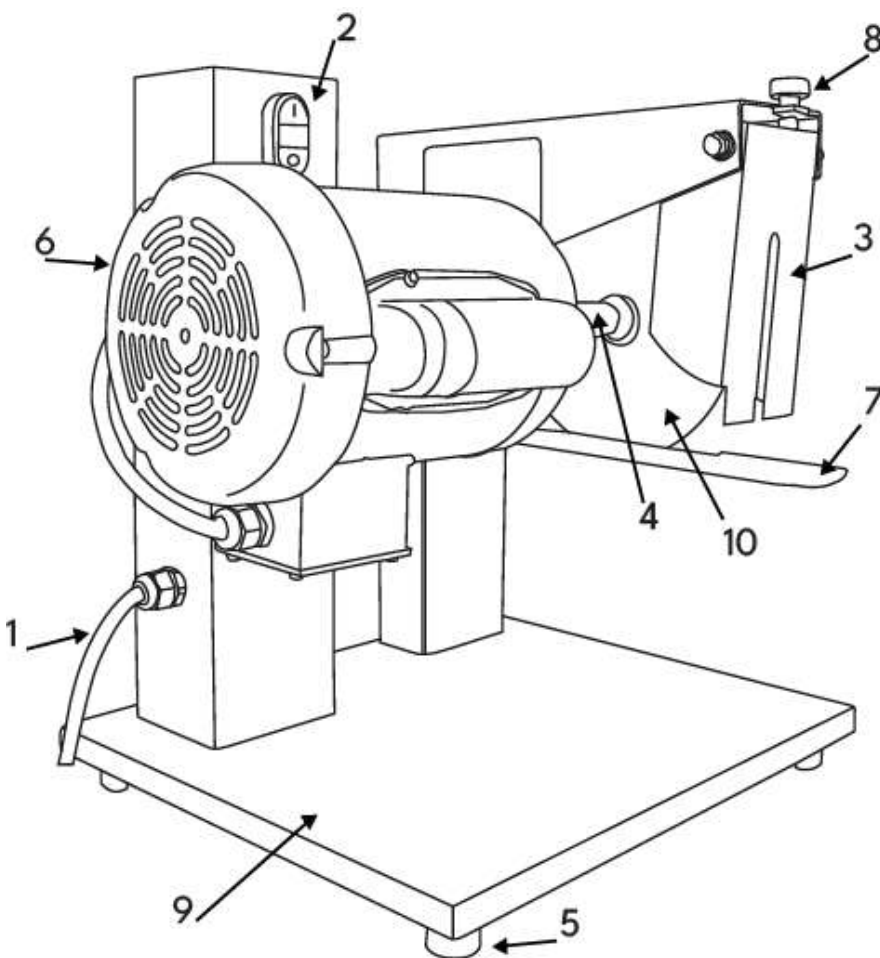

Parts

- 1.- Power cord
- 2.- ON- OFF button
- 3.- Knife protector
- 4.- Knife shaft
- 5.- Rubber legs
- 6.- Motor
- 7.- Knife guide
- 8.- Knob
- 9.- Base
- 10.- Knife (Blade)

Caution: Be careful manipulating the poultry cutter, the blade is sharp and with no protection and may cause accidents. Use cut resistant steel gloves.



It is extremely important that you and/or the equipment operator carefully read the contents of this operation, maintenance and service manual

Installation

Before plugging in the electrical outlet follow these steps for preparation and assembly (Do not follow the steps when plugged in).

- A. Place the rubber legs in the base.
- B. Place the machine in a leveled, clean surface. **Note:** For a perfect performance, make sure the voltage requirements, (usually 115V~ (+/-10%) 50/60HZ), matches the voltage where the machine will be placed. In case of needing a change in voltage, (220 volts), contact your dealer.
- C. Connect the poultry cutter near the power source, close enough to unplug easily when needed. .



Do not let untrained personnel manipulate, it may cause accidents.

Operation

IMPORTANT: While using for the first time the poultry cutter, clean by cutting a couple of slices por scrap product (Ex. a potato, carrot, etc). to make sure the blade is free of any debris.

1. Turn on the machine pressing the ON/OFF button (2)*.
2. Hold the product with both hands and slide it against the blade (10) using the knife guide (7) as support.
3. After the cuts, place the product in a tray and repeat.

NOTE: The poultry cutter is equiped with a microswitch that wont allow the motor run while the knife protector (3) is not in place.

Cleaning

NOTE: It is recomendado to clean the machine daily, using gentle soap, a damp cloth or a soft brush. Remove soap with water.

DO NOT CLEAN THE MACHINE WITH A WATER HOSE.

Do not use chlorine or other substances that might deteriorate the stainless steel surface.



It is extremely important that you and/or the equipment operator carefully read the contents of this operation, maintenance and service manual

1. Lift the knife protector by the knob to clean the inner part of the protector (Use cut resistant steel gloves).
2. Clean the knife, knife guide and knife protector using a damp cloth.
3. Clean the remaining parts using the same procedure.

Maintenance

Sharpening the knife (blade). (Fig 2).

1. Clean the knife with vinegar.
2. Turn on the poultry cutter.
3. Use a long sharpening steel (30 cm/12") to let you work close enough to the blade without the risk of an accident.
4. Hold the sharpening steel above the knife guide and slide it towards the blade below the protector.
5. Make contact with the knife with the sharpening steel for about 10 to 15 seconds with a 4° or 5° angle.
6. Repeat steps 4 & 5 to the other side of the knife.
7. Test the knife's sharp by cutting a piece of scrap product.

The resharpening process depends on the ability and experience of the operator.



It is extremely important that you and/or the equipment operator carefully read the contents of this operation, maintenance and service manual.

Sharpening (Fig. 2)

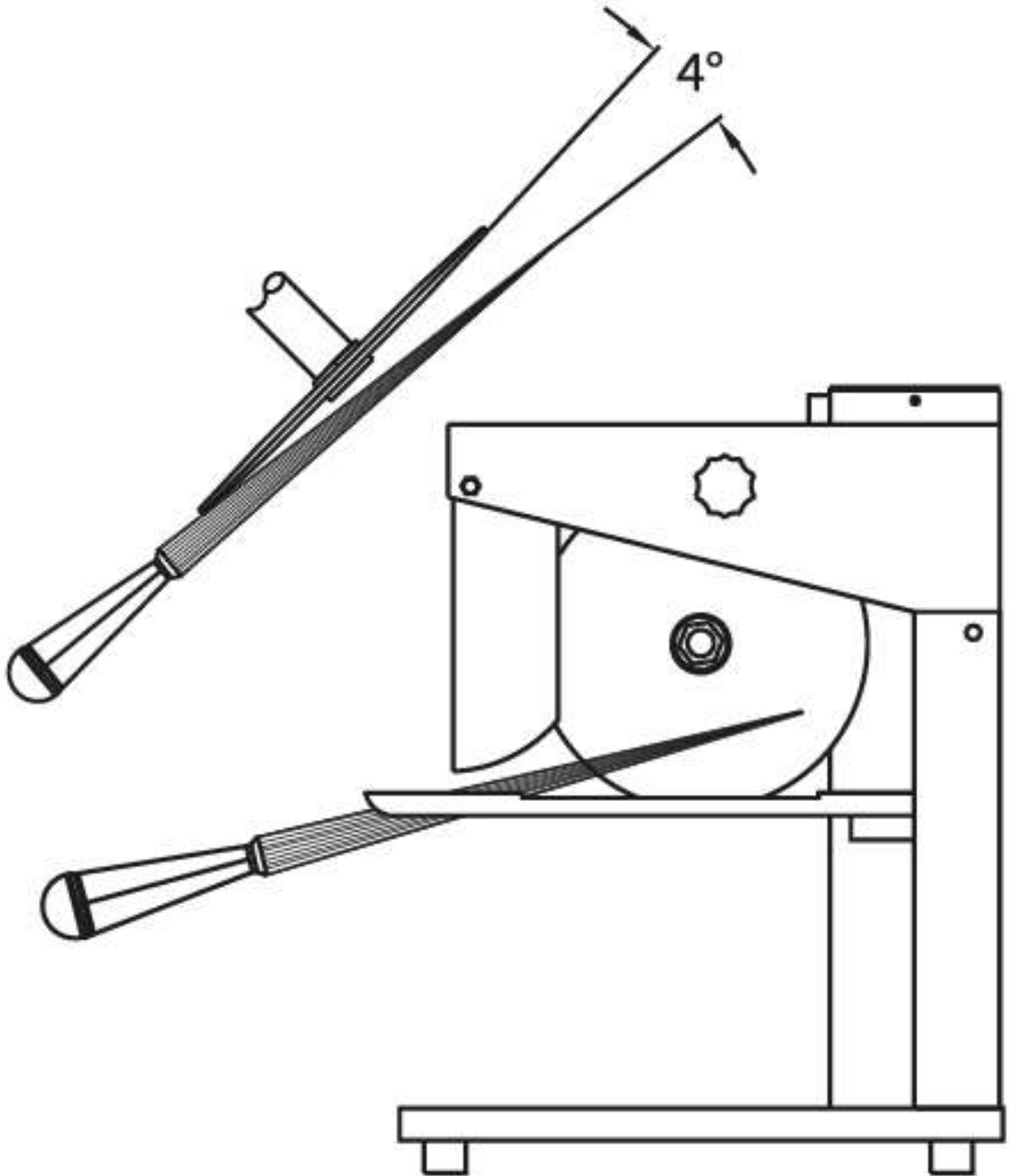



It is extremely important that you and/or the equipment operator carefully read the contents of this operation, maintenance and service manual.

Electric diagram

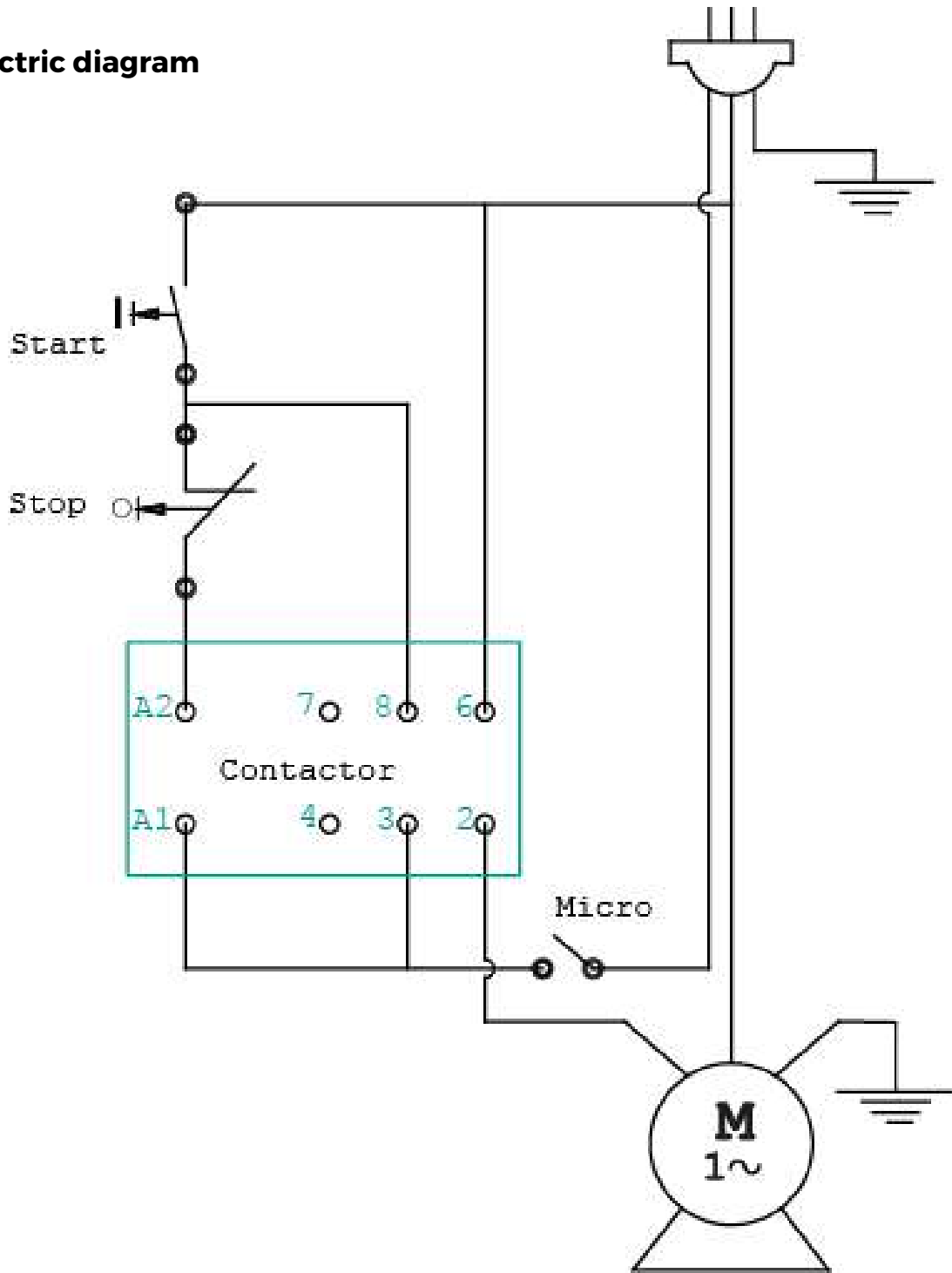

GROUND LINE (GREEN CABLE)

LIMITED WARRANTY (1) YEAR WARRANTY

Meat Gear warrants this product against defects in materials or workmanship for a period of one year from the date of original purchase.

Should any manufacturing defect be discovered within one year from date of purchase, you must deliver the entire product to the MEAT GEAR dealer that sold it or to a MEAT GEAR service center in its original packaging or in packaging affording an equal degree of protection, along with proof of purchase. MEAT GEAR will at its option, repair or replace or an exchange basis with an equal or equivalent unit. The defective unit, without charge for parts and labor. The transportation and insurance charges to and from the MEAT GEAR service center are not included in this warranty.

WHAT THIS WARRANTY DOES NOT COVER

This warranty covers only normal consumer use in Canada and the United States. This warranty does not cover worn parts, which die to the nature of the machine, have a limited usable life, and have to be replaced on a use and wear basis, nor:

- A) Damage caused by disasters such as fire, flood, lightning, improper electrical current.
- B) Improper or inadequate installation.
- C) Improper or inadequate maintenance.
- D) Unauthorized modification or misuse.
- E) Damage caused by service other than by an authorized MEAT GEAR service center.

LIMITATIONS OF WARRANTY

NEITHER MEAT GEAR OR ANY THIRD PARTY SUPPLIERS MAKES ANY OTHER WARRANTY OF ANY KIND, WHETHER EXPRESS OR IMPLIED, WITH RESPECT TO MEAT GEAR PRODUCTS. THIS WARRANTY IS EXCLUSIVE AND IN LIEU OF ALL OTHER EXPRESS WARRANTIES AND UNLESS STATED HEREIN, ANY STATEMENTS OR REPRESENTATIONS MADE BY OTHER PERSON OR FIRM ARE VOID. THE DURATION OF ANY IMPLIED WARRANTIES OF MERCHANTABILITY OR FITNESS FOR A PARTICULAR PURPOSE ON YOUR MEAT GEAR PRODUCT SHALL BE LIMITED TO THE DURATION OF THE EXPRESS WARRANTY SET FORTH ABOVE, EXCEPT AS PROVIDED IN THIS WRITTEN WARRANTY NEITHER MEAT GEAR NOR TIS AFFILIATES SHALL BE LIABLE FOR ANY LOSS, INCONVENIENCE, OR DAMAGE, RESULTING FROM THE USE OR INABILITY TO USE THE MEAT GEAR PRODUCT, WHETHER RESULTING FROM BREACH OF WARRANTY OR ANY OTHER LEGAL THEORY.

Some states do not allow limitations on how long an implied warranty lasts and some states do not allow the exclusion or limitation or incidental or consequential damages, so the above limitation and exclusion may not apply to you. . This warranty gives you specific legal rights, and you may also have other rights which vary from state to state.

HOW TO OBTAIN WARRANTY AND SERVICE

- 1.- Refer to the trouble shooting guide in your owners manual. This list might solve your problem.
- 2.- Call the MEAT GEAR dealer that sold the product within 30 days after you find a problem in the product.
- 3.- Call our technical support team at 832-917-1547 where they can help you with any question you need.
- 4.- If you have to ship a MEAT GEAR service center be sure to obtain a Service order number from the MEAT GEAR service center at +1 (800) 824-1644 / (832) 917-1547.
- 5.- Arrange for the delivery of the product to the authorized MEAT GEAR service center. Products shipped to the service station must be insured and safely and securely packaged, preferably in the original carton, and a letter explaining the defect and also a copy of the bill of sale or other proof of purchase must be enclosed.
- 6.- Make sure to include inside the package a complete description of the defect or trouble with the unit and complete name, address, and more phone numbers of who to contact for more questions and who to ship to.
- 7.- And also make sure to clearly write outside of the package the service order number and the full address for the MEAT GEAR service center.

Contact
MEAT GEAR
www.meatgear.mx
+1 (800) 824-1644 / (832) 675-9699 / 832-917-1547
sales@meatgear.mx

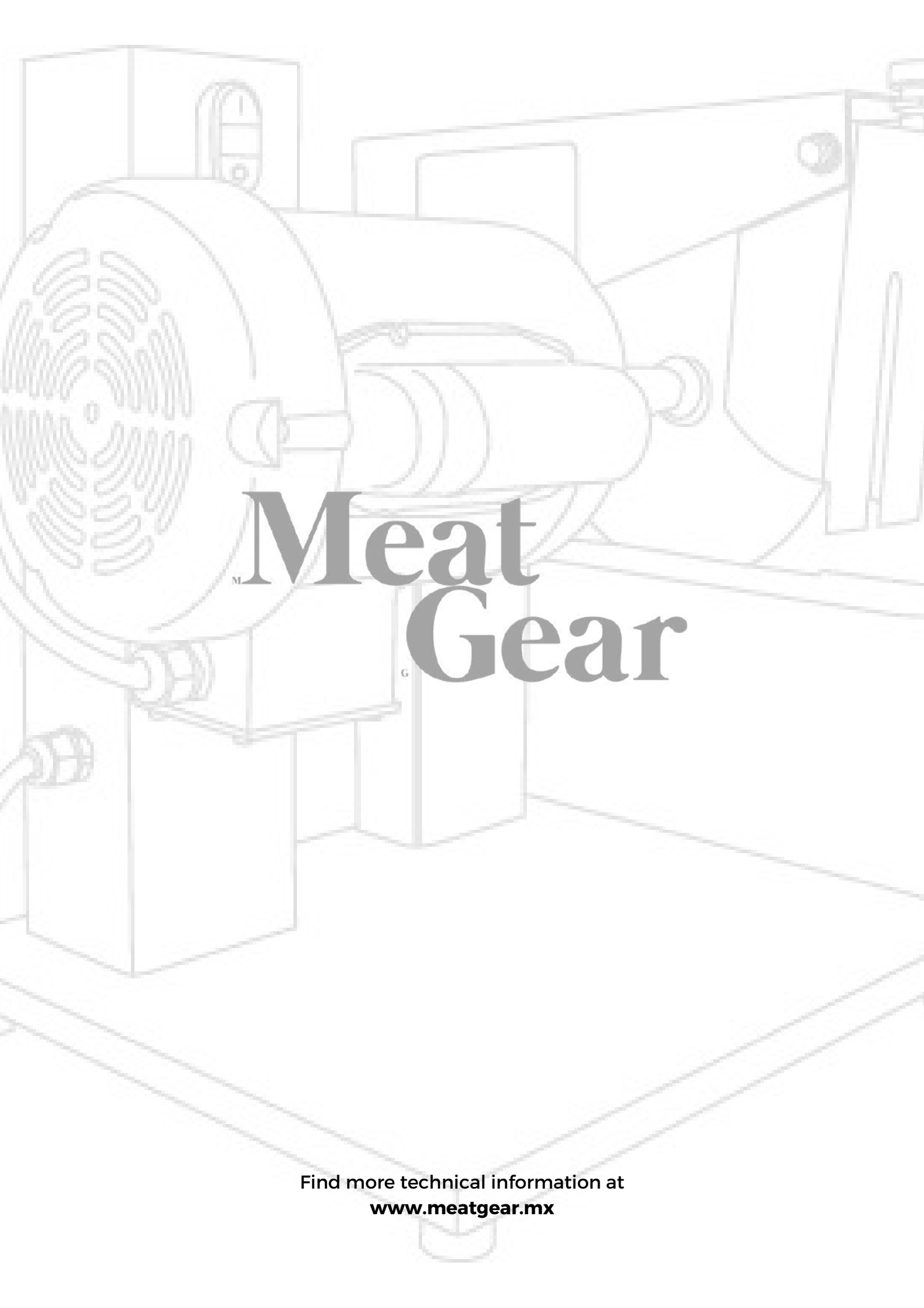

^MMeat ^GGear

Find more technical information at
www.meatgear.mx